



ASSEMBLY GUIDE

OSF PROFILE

SADEV BALUSTRADE CONCEPT **RANGE**



ASSEMBLY
GUIDE VIDEO

ORDER CONFORMITY

We advise you to read this manual completely and carefully before working on the equipment.

Using the delivery note, check the conformity of the delivery before any other intervention.

ACTIVATE YOUR PRODUCT WARRANTY

Register directly on our website
www.sadev.com/maintenance-and-warranty

Product description

Composition of a box

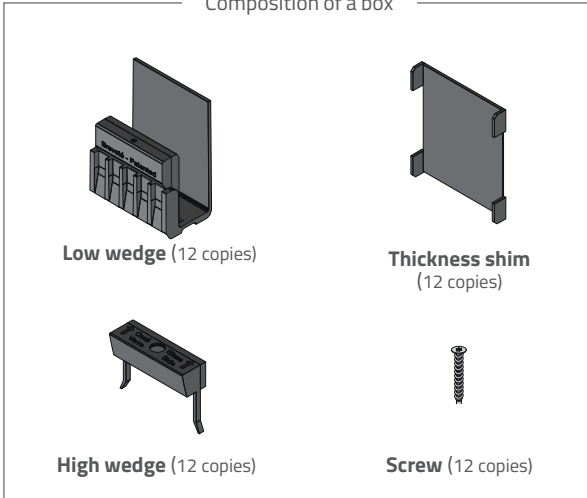

Number on the wedge	Reference	Glass composition	Glazing thickness [min.; max.]
3	0090SF-K12-0606	6.6	12.4 > 13.9
4	0090SF-K12-0808	8.8	16.2 > 17.6
1	0090SF-K12-1010	10.10	21.2 > 21.6

IMPORTANT



Control that the glass thickness is compatible with the wedges before installing it in the rail.

GUIDELINES

The balustrade assembly must comply with these assembly instructions, as well as with the usual safety and usage precautions.

Any modification or degradation of SADEV's products disengage the responsibility of our company.



Available on [sadev.com](https://www.sadev.com)

SUMMARY

A	RAIL FIXING	8
B	PROFILE CONNECTION	10
C	INSTALLATION OF LOW WEDGES	11
D	SNAP-FIT GASKET AND GLASS INSTALLATION	12
E	GLASS SPACER	13
F	THICKNESS SHIMS INSTALLATION	14
G	HIGH WEDGES INSTALLATION	15
H	CLADDING AND GASKET INSTALLATION ON THE ACCESSIBLE SIDE	16
I	END CAPS INSTALLATION	17
J	HANDRAIL INSTALLATION	18
K	REMOVING THE WEDGES MAINTENANCE	21

Tools required for assembly

- **ROTARY HAMMER**
- **DRILL BITS ADAPTED TO THE STRUCTURE AND FASTENING COMPONENTS**
drilled profile 15mm diameter.
- **TIGHTENING TOOL AND TORQUE CONTROL** according to the type of dowel used.
- **DYNAMOMETRIC SCREWDRIVER PACK + TORX BIT**
Ref.: OUT-TRVS-2NM - Tightening torque: 2 Nm.
- **CORDLESS SCREWDRIVER**
- **MALLET**
- **SADEV CLEANING SET** - Ref. : 7OUT-KITNET.
- **OSF PROFILE LEVELING SHIMS**
- **LEVEL TOOL**

HOW TO MADE A WATER DRAINAGE

Water drainage in the OSF guadrail is carried out by drilling the alluminium rail and/or the finishing plugs according to the technical drawings below.

As the rail must be laid straight (without deformation) the water drains off naturally on both sides of it. Depending on the situation, $\varnothing 8$ mm holes can be drilled on site in the plug and/or profile for water drainage.

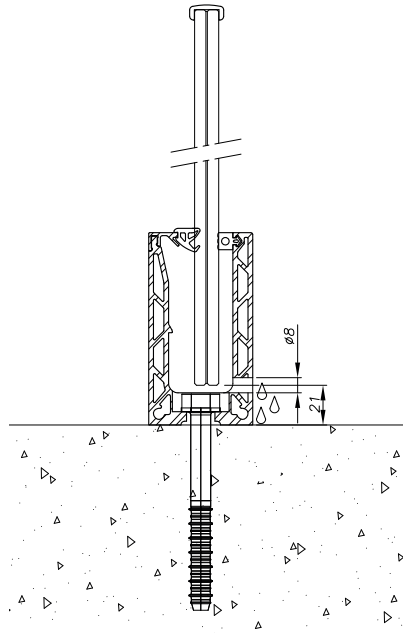
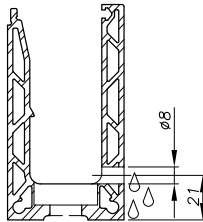
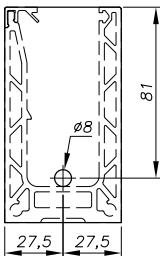

Floor mounting

HOW TO MADE A WATER DRAINAGE

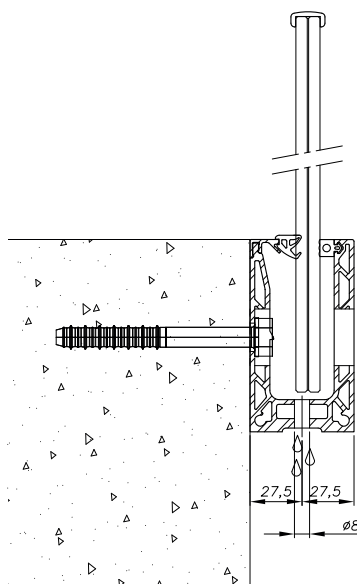
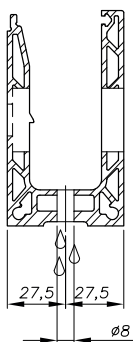
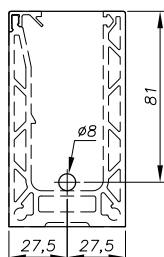

Lateral mounting

RAIL AND CLADDING EXPANSION INFORMATIONS



Expansion is taken into account to ensure that the rails and claddings are held securely in place. The building's expansion gasket must be respected in the balustrade assembly.

During the balustrade assembly, **you must consider the coefficient of thermal expansion.**

What does it refer?

The coefficient of thermal expansion is the expansion at constant pressure of the railing caused by its heating or cooling.

ALUMINUM						
2 500mm		Maximum profile temperature				
Profile temperature during assembly		40°C / 104°F	50°C / 122°F	60°C / 140°F	70°C / 158°F	80°C / 176°F
	-20°C / -4°F	4mm	4mm	5mm	5mm	6mm
	-10°C / -14°F	3mm	4mm	4mm	5mm	5mm
	0°C / 32°F	3mm	3mm	4mm	4mm	5mm
	10°C / 50°F	2mm	3mm	3mm	4mm	4mm
	20°C / 68°F	1mm	2mm	3mm	3mm	4mm
	30°C / 86°F	1mm	1mm	2mm	3mm	3mm
5 000mm		Maximum profile temperature				
Profile temperature during assembly		40°C / 104°F	50°C / 122°F	60°C / 140°F	70°C / 158°F	80°C / 176°F
	-20°C / -4°F	7mm	8mm	9mm	11mm	12mm
	-10°C / -14°F	6mm	7mm	8mm	9mm	11mm
	0°C / 32°F	5mm	6mm	7mm	8mm	9mm
	10°C / 50°F	4mm	5mm	6mm	7mm	8mm
	20°C / 68°F	3mm	4mm	5mm	6mm	7mm
	30°C / 86°F	1mm	3mm	4mm	5mm	6mm

A RAIL FIXING

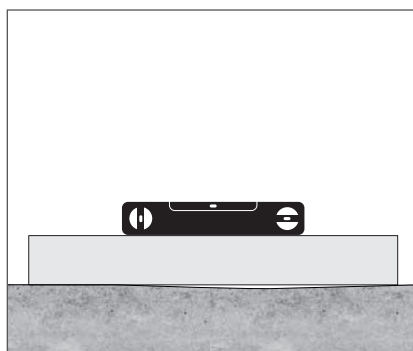

1 - Check the flatness and conformity of the support with a ruler.

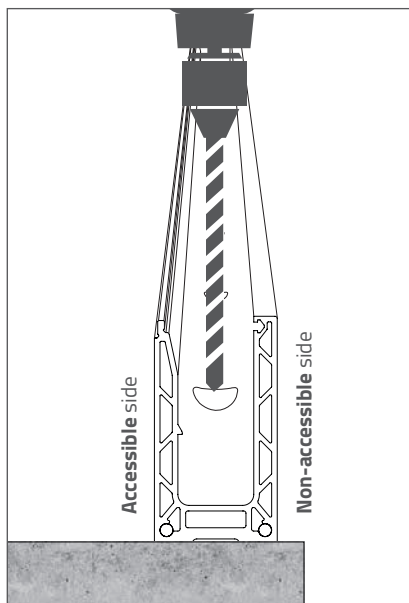

2 - Drill the support with a tool adapted to it.

INFORMATIONS

Possible supports: concrete, wood, metal, others...

The support must be able to support the loads induced by the balustrade.

A RAIL FIXING

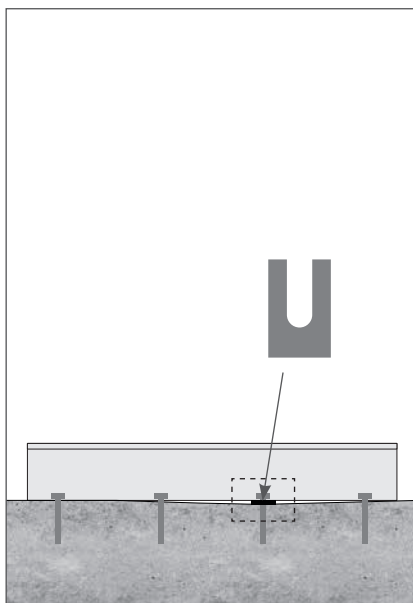

3 - If it's an uneven surface, level the profile by adding our OSF profile leveling shims.

These wedges must be placed at the level of the fasteners (it is possible to put several of them).

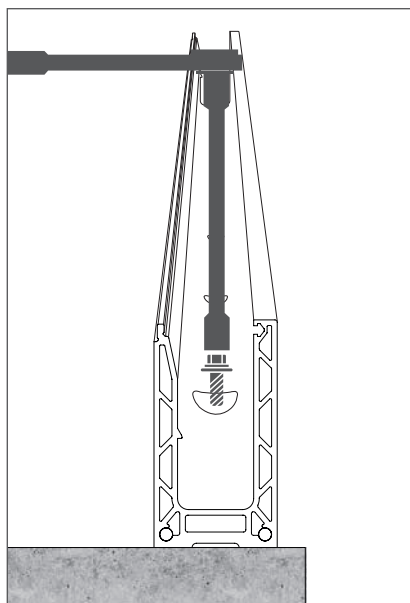

4 - Adjust and fix the rail with the appropriate wrench to the fixing pins.

Respect the tightening torque and the mounting recommendations recommended by the manufacturer.



CAUTION:

Be sure to take into account the expansion gaps between the OSF profiles and the support.

MORE INFORMATION ON PAGE 6.

A RAIL FIXING

LATERAL MOUNTING



CAUTION: Be sure to take into account the expansion gaps between the OSF profiles and the support. **MORE INFORMATION ON PAGE 6.**

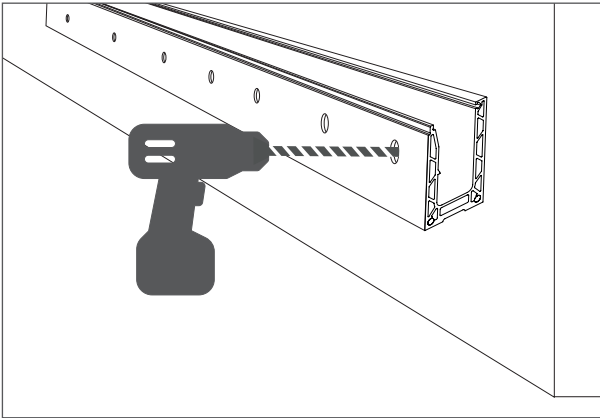

- 1 - Drill the support with a tool adapted to it.
- 2 - If the support is irregular, level the profile by adding our osf profile leveling shims. These wedges must be placed at the level of the fasteners (it is possible to put several of them).

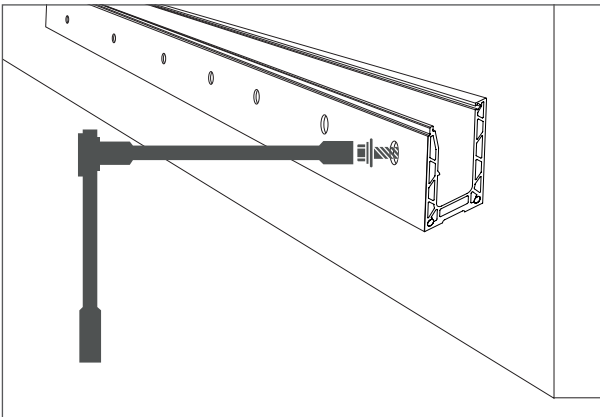

- 3 - Adjust and fix the rail with the appropriate wrench to the fixing pins. Respect the tightening torque and the mounting recommendations recommended by the manufacturer.

B PROFILE CONNECTION

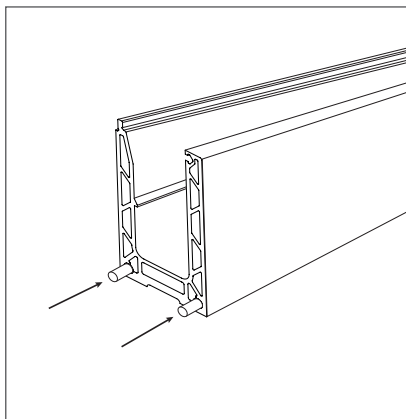

1 - Fit 2 SADEV pins connector in the rail section holes.

Location of spring pins

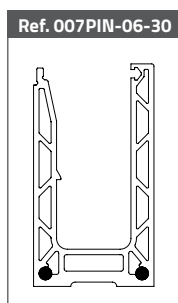

0090SF-R70 / 0090SF-R80

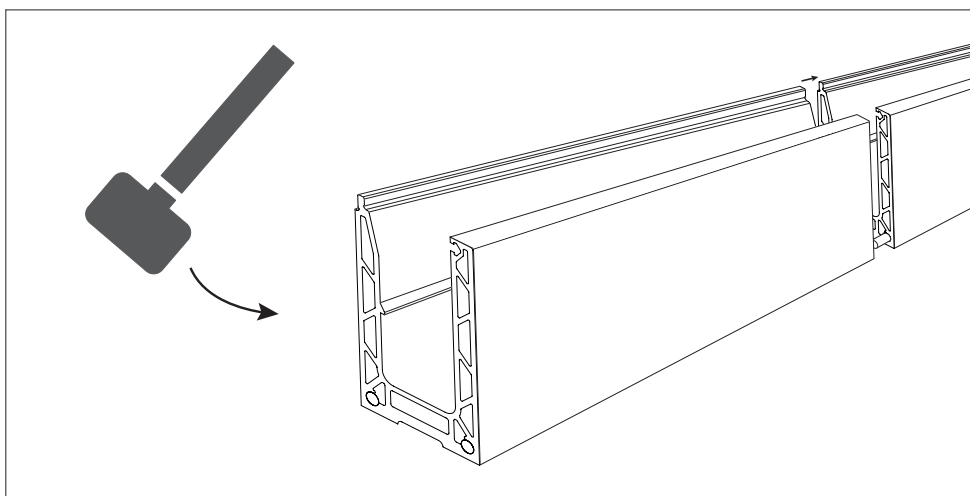

2 - Connect the rails together by using a mallet.

D SNAP FIT GASKET AND GLASS INSTALLATION

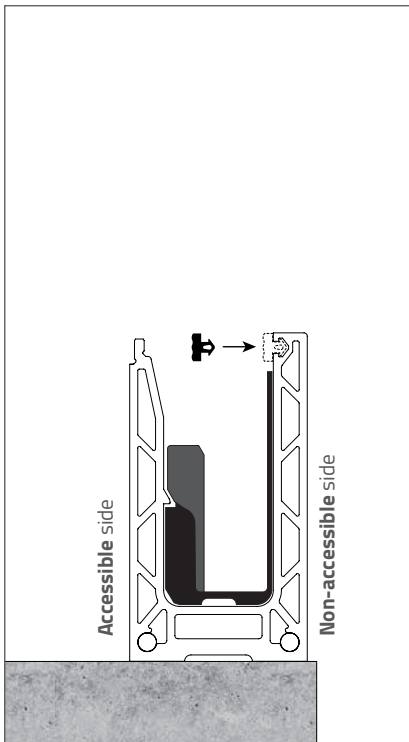

1 - Press the Snap-fit gasket into the non accessible side.

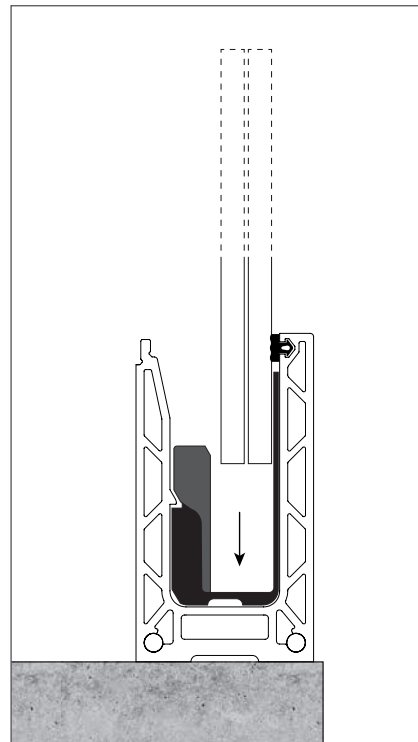

2 - Lift the glass pannel inside the wedges.

E GLASS SPACER

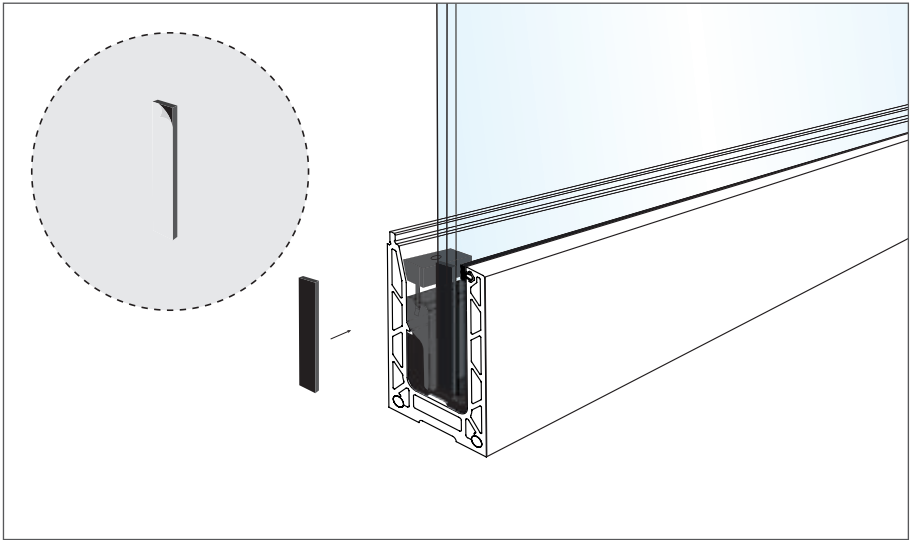

1 - Remove the protection from the adhesive. Stick the SADEV spacer on the edge of the glass, on the bottom right-hand corner flush with the glass.

The spacers have different functions:

- To have a regular space between the glass panels.

The spacers are 5 mm wide. If you need a larger gap, you can stick the spacers together to obtain spacings of 10, 15 mm... .

F THICKNESS SHIMS INSTALLATION

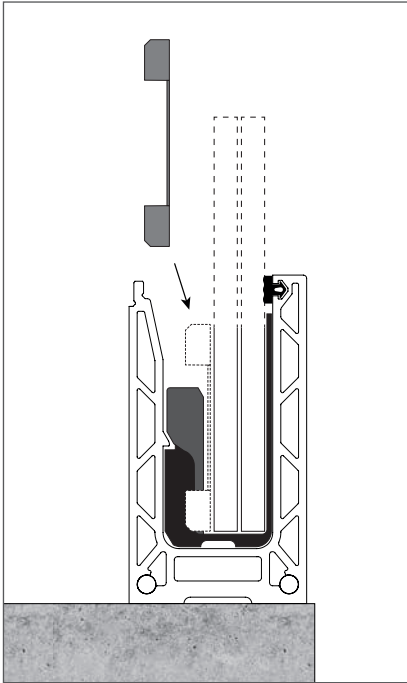

Add the thickness shims to fill the space between the glass and the wedges according to the thickness of your glasses.

CAUTION: It must be easily inserted. DO NOT USE FORCE TO INSERT IT (otherwise it is not useful).



Wedge side

Glass side

- 1 - PUT the glass on the outside
- 2 - Insert the thickness shim between the glass and the wedge

Kit Reference	Glass composition	Glazing thickness	Put the thickness shim
009OSF-K12-0606	6.6	12.4 > 13.2 mm	A
009OSF-K12-0808	8.8	16.2 > 16.8 mm	A
		16.9 > 17.4 mm	No thickness shim
009OSF-K12-1010	10.10	20.2 > 20.8 mm	A
		20.9 > 21.6 mm	No thickness shim

G HIGH WEDGES INSTALLATION

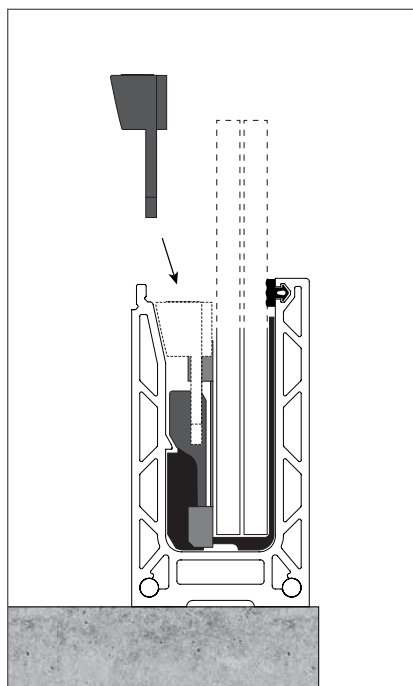
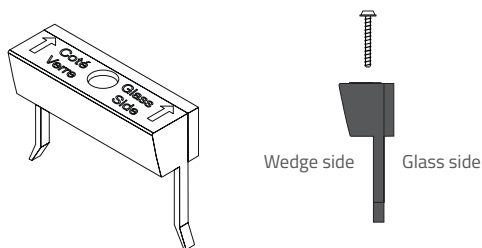

1 - Insert the high wedge.

Pay attention to the direction of the arrows.

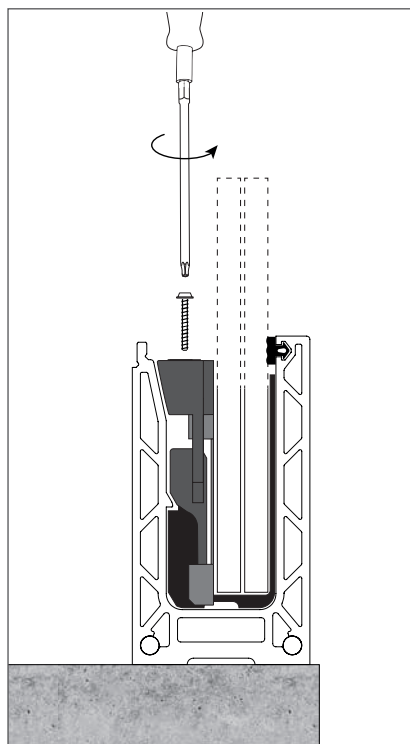

2 - Insert the screw in the provided place

3 - Screw with the screwdriver to fix the glass.

Use the torque screwdriver (Ref.: 007-TRVS-2 NM) to control the tightening torque: 2 Nm.

H CLADDING AND GASKET INSTALLATION ON THE ACCESSIBLE SIDE.

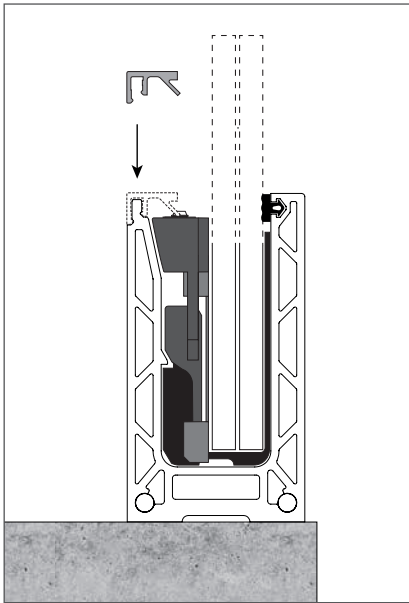

1 - Clip the cladding.

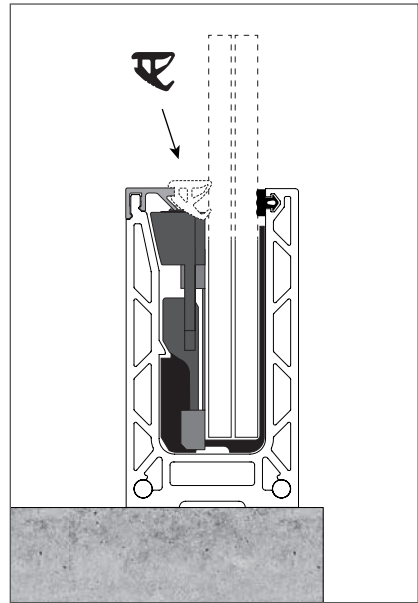

- 1 - Add the press-in gasket between the cladding and the glass.
- 2 - Do not stretch the gasket by clipping it.



CAUTION :
Be sure to take into account the expansion gaps between the OSF profiles and the support.
MORE INFORMATION ON PAGE 6.



The gasket must be correctly installed along the entire length of the cladding. It is advisable to align the junctions of the cladding with those of the rails.

I END CAPS INSTALLATION

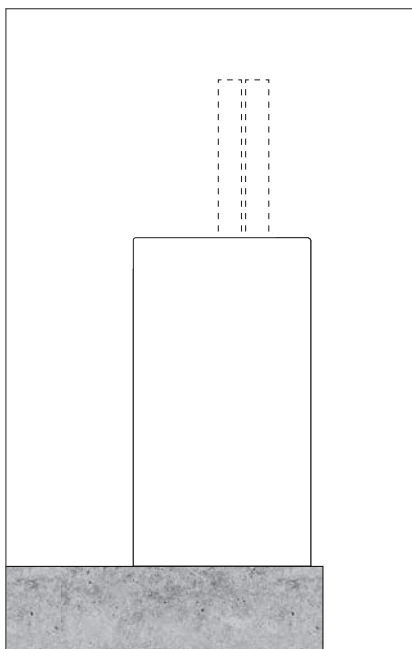

- 1 - Cleaning the rail with the Sadev cleaning set. Ref. : 7OUT-KITNET before installing the end cap.
- 2 - Remove the adhesive protection.
- 3 - Press the end cap at the end of the rail.

J INSTALLATION OF HANDRAIL

U Profile

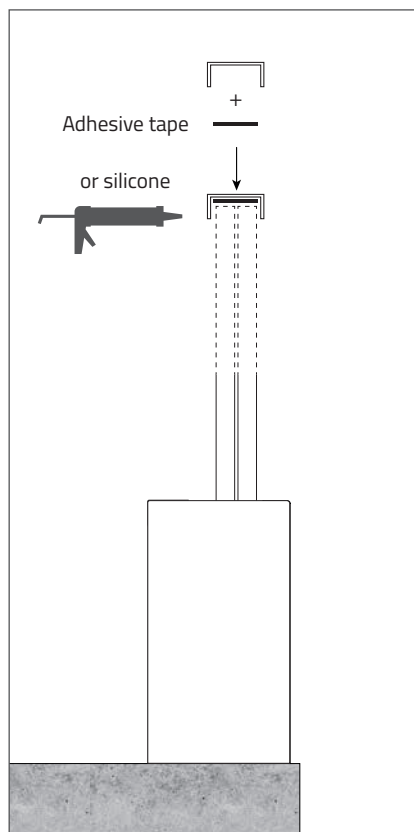

Tube with slot for glass

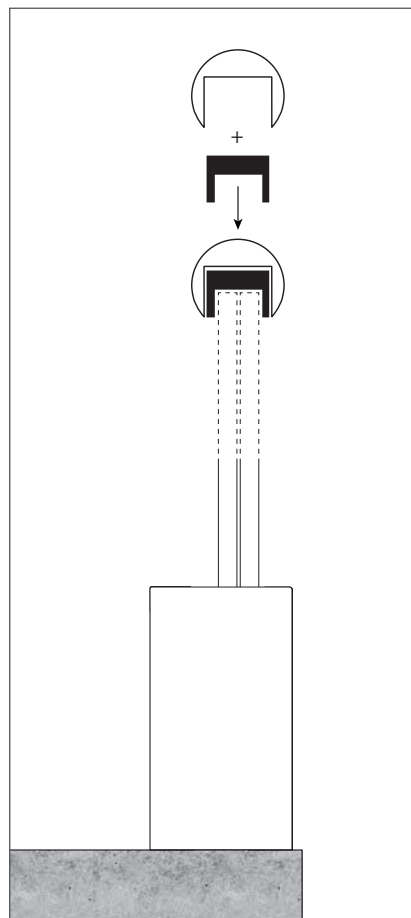

J INSTALLATION OF HANDRAIL

Connector

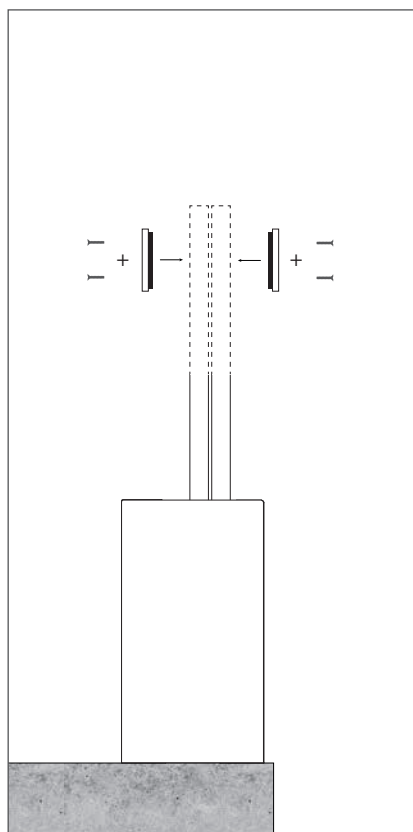

Bracket

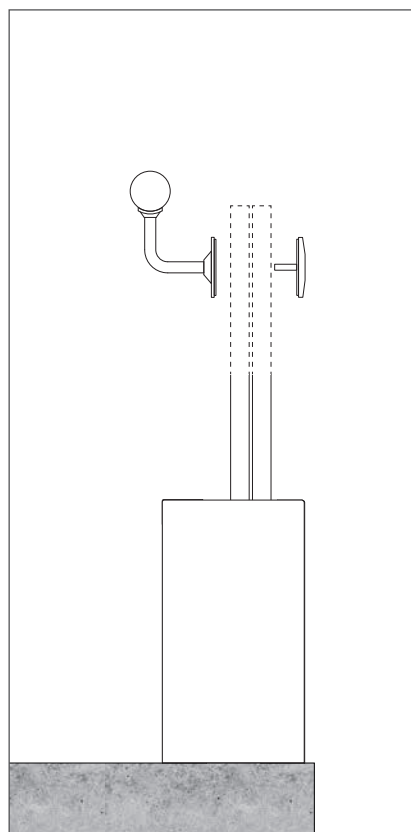

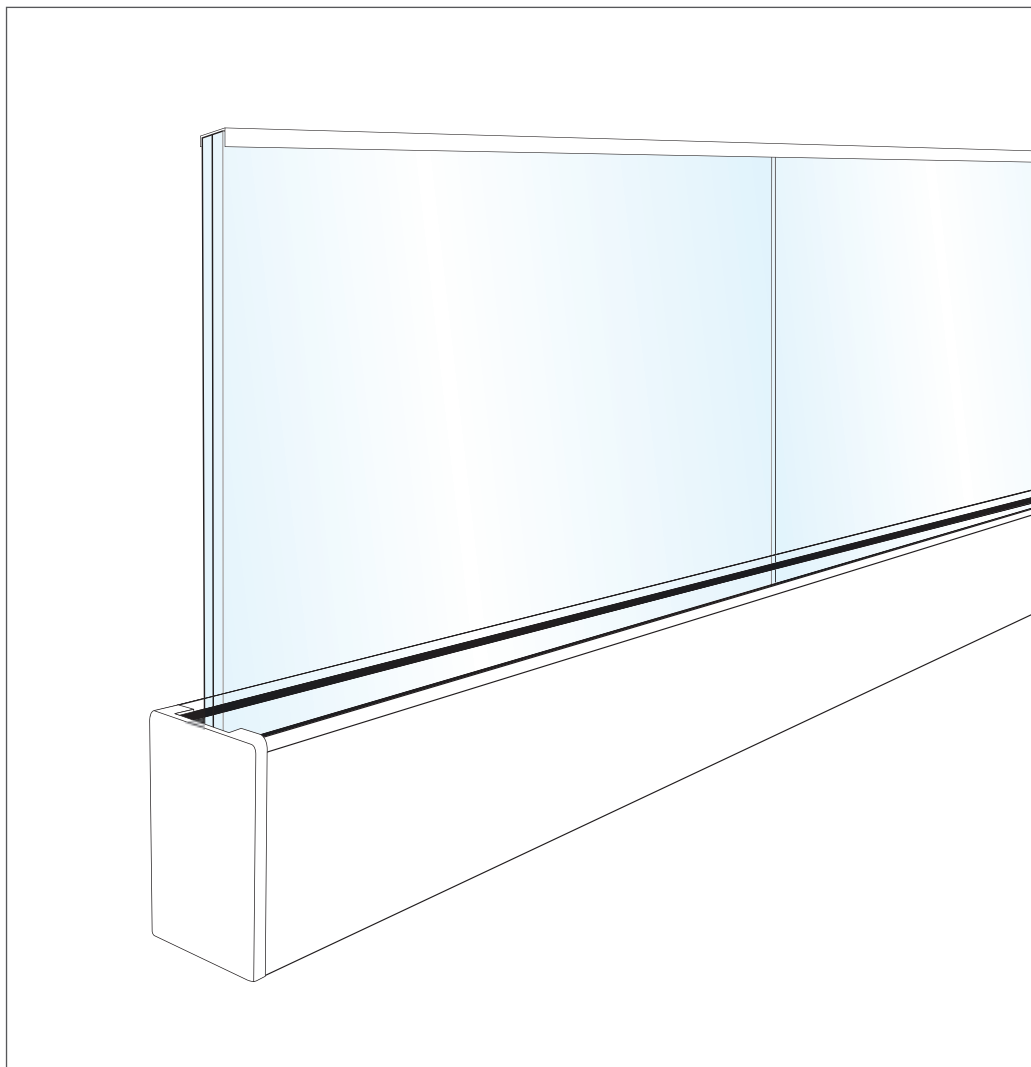

You have successfully assembled your balustrade!

K REMOVING THE WEDGES **MAINTENANCE**

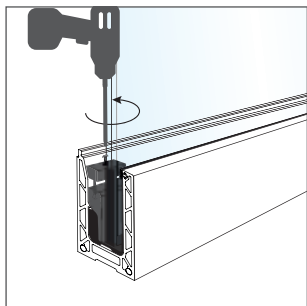

1 - After removing the cladding and gasket, unscrew the screws 1 cm high.

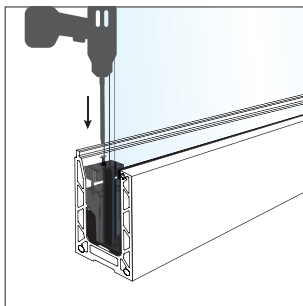

2 - Apply a force on the screw in order to lower the intermediate wedge.

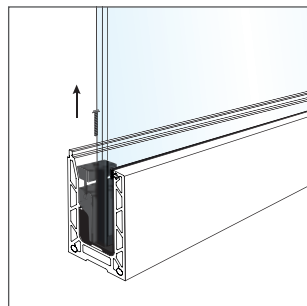

3 - Finish unscrewing the screw and remove it

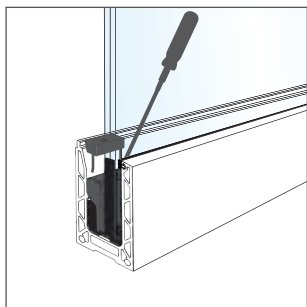

4 - Using a screwdriver, pry between the intermediate and upper wedge to remove the high wedge.

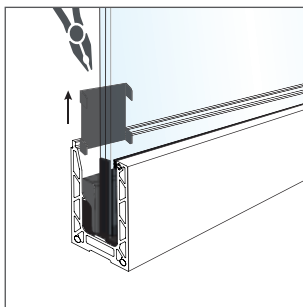

4 - If thickness shims have been added, you can use pliers to remove them

INFORMATIONS

Once all the high wedges have been removed from the rail, remove the glass.

Replace all wedges. The wedges cannot be reused.



ASSEMBLY GUIDE OSF PROFILE

Available on [sadev.com](https://www.sadev.com) 



76 Chemin des Poses | 74330 POISY | FRANCE |
Tél. : +33 (0)4 50 08 39 00 | info@sadev.com | www.sadev.com